



# **EQUIPMENT SPECIFICATIONS**

## **CITY BLENDS CONTACT**

**STEPANIE SUDDARTH**

**877.5.BLENDS**

**STEPHANIE@CITYBLENDS.COM**

## **EQUIPMENT CONTACT**

**TODD SPARKS**

**866.345.8642 EXT. 17**

**TODD.SPARKS@DIRECTSOUTH.COM**



## **BD8-W DIMENSIONS:**

17.75"W x 11.5"D x 19"H

Clearance for air flow required.

## **HOW THE BD8 WORKS**

Your recipe is entered into the BD8 by accessing the programming mode of the microprocessor. Input up to 32 recipes into memory. To make a drink, enter the recipe number into the touchpad.

The microprocessor directs peristaltic pumps to draw ingredients through external supply lines. The pumps precisely meter product into a blender jar containing ice in the blending chamber. Water, if desired, is added to complete the recipe.

As ingredients are dispensed into the blending jar a 3.5 peak horsepower motor begins the blending process. A pre-programmed blend cycle speeds the delivery of your drink—ready to serve.





## **ADDITION BINS**

Stacking Dispensers, 4w x 11d x 7h  
8 - #927 recommended. Brackets are included.

## **PROTEIN BINS**

Top Load Single Bin 4 1/4 x 12 x 16 1/2  
Top Load Triple Bin 13 X 12 X 16 1/2  
2 - #946 recommended. Brackets are included.

## **CONTACT**

Todd Sparks  
todd.sparks@directsouth.com  
866-345-8642 ext. 17





# TUC-Series: Standard Depth Undercounter Units

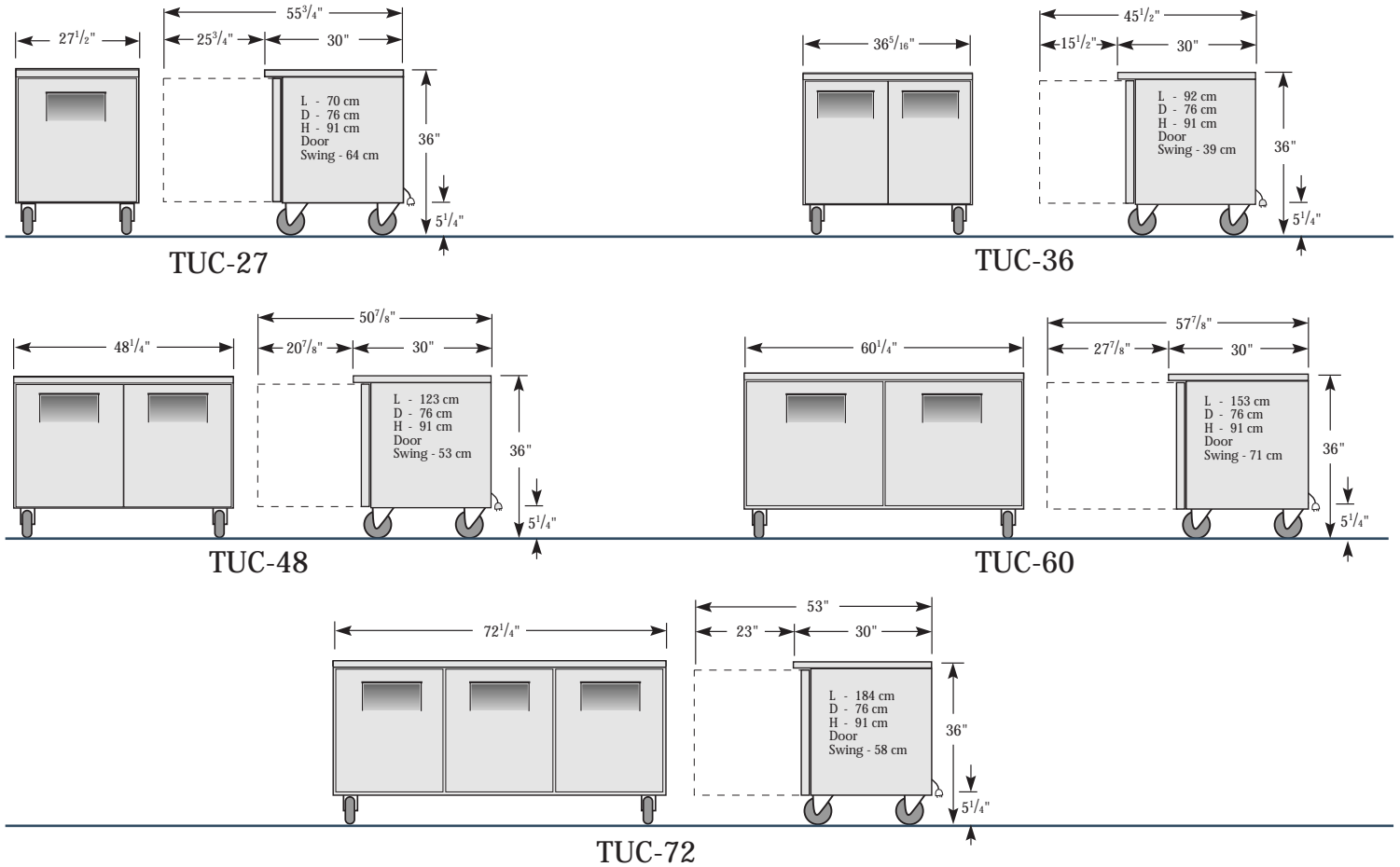

Rough-In Data													
Model	Doors	Capacity (Cu. Ft)	# of Shelves	Dimensions (inches)			HP	Volts	PH	Amps	NEMA Config.	Cord Length (feet)	Crated Weight
				L	D	H							
TUC-27 (1, 2, 3, 4)	1	6.5	2	27 1/2	30	36	1/5	115	1	4.0	5-15	7	161
TUC-36	2	8.5	4	36 1/2	30	36	1/5	115	1	4.0	5-15	7	161
TUC-48 (1, 2, 3)	2	12	4	48 1/4	30	36	1/3	115	1	9.0	5-15	7	243
TUC-60 (1, 2, 3)	2	15.5	4	60 1/4	30	36	1/3	115	1	8.0	5-15	7	287
TUC-72	3	19	6	72 1/4	30	36	1/2	115	1	11.0	5-15	7	350

- (1) Available in drawered model
- (2) Available in freezer model
- (3) Available in glass door model
- (4) Available in glass door freezer

Specifications subject to change without notice.

## Standard Features

- Stainless steel front, top and sides.
- White anodized aluminum interior and stainless steel bottom.
- Oversized and balanced, environmentally friendly refrigeration system - holds 32 F-38 F (134A, refrigerator), -10 F (R404A, freezer).
- Front breathing
- Work surface 36" high.
- Recessed handles on solid door models; glass door models feature triple pane glass and 12" aluminum handles.
- Door swings within cabinet dimensions.
- Adjustable vinyl coated wire shelves.
- Epoxy coated evaporator.
- Aluminum finished back.
- Slide out compressor can be serviced easily and accessed by a single repairman.
- Self-contained system.
- Foamed-in-place high density polyurethane insulation (CFC free).
- 5" castors standard equipment.
- 1 year parts & labor warranty (USA)
- 5 year compressor warranty

## Optional Accessories

- Drawered models
- Cutting board
- Stacking collar
- 6" Legs available
- 2 1/2" Castors available

Clearance Required For Coolers (USA)	
Sides Inches/mm	Rear Inches/mm
0 / 0	2 / 50

## TRUE FOOD SERVICE EQUIPMENT

# SCOTSMAN

UNDERCOUNTER COMPACT FLAKER WITH STORAGE

## A F E 4 0 0

VOLUME PRODUCTION • 24 HOUR

Based on Air/Water Temperatures	Air-Cooled		Water-Cooled	
	70°/50° lbs.	90°/70° lbs.	70°/50° lbs.	90°/70° lbs.
AFE400	395/179	300/160	395/179	310/141



### DEPENDABLE PERFORMANCE IN ANY CONDITION

- Delivers steady flow of ice for fast recovery of ice supply.
- 7-ft. power cord for quick installation.
- Completely serviceable from the front side.
- 3-piece cabinet is easily removable from front.
- Rear utility connections.
- Cabinet constructed of durable rust-free rotocast plastic.

### WARRANTY *See your dealer for complete warranty details.*

- 2 years parts on all components.
- 2 years labor on all components.
- 5 years parts on compressor.



#### UNDERCOUNTER INSTALLATION

Adapts to numerous under-counter applications. Fits under any 40" counter.



#### SLIDE AWAY ACCESS DOOR

Provides convenient and easy access to ice.

This product qualifies for the following listings:



 **Scotsman**<sup>®</sup>

# Ice Machine Specifications

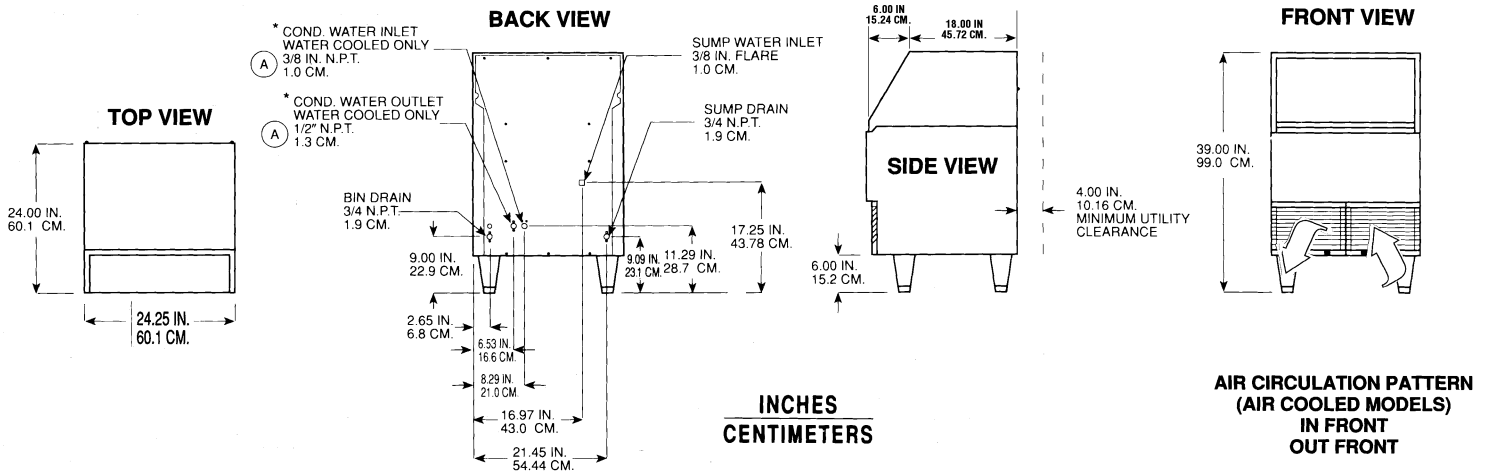

INSTALLATION NOTE: Allow 6" minimum space at left side and back for ventilation and utility connections.

All models: Dimensions: W x D x H without legs (Add 6" height for legs): Unit: 24<sup>1</sup>/<sub>4</sub>" x 24" x 33" Shipping Carton: 27" x 27<sup>1</sup>/<sub>2</sub>" x 38"

Model Number	Condenser Unit	Bin Cap. lbs./kg.	Basic Electrical Volts/Hz/Phase	Max. Fuse Size or HACR Circuit Breaker	Comp. HP	Circuit Wires	Min. Circuit Ampacity	Shipping Weight lbs./kg.	Power Consumption KWH/100 lbs. 90°F/70° F	Water Usage Gallons/100 lbs. 90°F/70° F	
										Potable	Condenser
AFE400A-1A	AIR	80/36	115/60/1	15	1/4	2	CORD	185/84	5.4	12.0	-
AFE400W-1A	WATER	80/36	115/60/1	15	1/4	2	CORD	185/84	5.0	12.0	131.0

Finish: Rotocast grey plastic.  
 Refrigerant R-134A.

**LEGS SUPPLIED:**  
 Four black plastic legs screw into mounting plates on cabinet base. Provide 6" minimum height including adjustable leveling foot.

Scotsman's ice machines are not designed for outdoor installations. Scotsman remote condensers are designed for outdoor installations.

Machine requires voltage indicated on rating name plate. Failures caused by improper voltage are not considered factory defects. Extended periods of operation at temperatures exceeding limitations constitutes misuse under the terms of Scotsman Manufacturer's Limited Warranty, resulting in a loss of warranty coverage. Specifications and design are subject to change without notice.

Consult Your Local **SCOTSMAN** Representative At:

## IMPORTANT OPERATING REQUIREMENTS:

	Minimum	Maximum
Air Temperatures	50°F (10°C)	100°F (37.7°C)
Water Temperatures	40°F (4.4°C)	100°F (37.7°C)
Water Pressures	20 PSIG	120 PSIG
Electrical Voltage	-5%	+10%

**YOU'LL VALUE THE DIFFERENCE.™**

775 Corporate Woods Parkway • Vernon Hills, IL 60061 • 1-800-SCOTSMAN • (847) 913-9844  
 Visit our website at: [www.scotsman-ice.com](http://www.scotsman-ice.com) • E-mail: [customer.service@scotsman-ice.com](mailto:customer.service@scotsman-ice.com)

 **Scotsman**®



STAINLESS STEEL  
**REGALINE SINKS**  
**T9 SERIES**

**NEW** *Tile Edge Design*

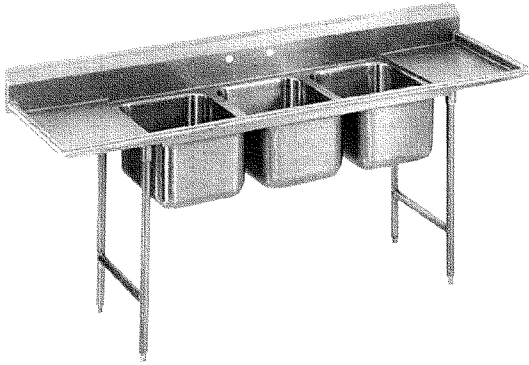

**FEATURES:**

Tile edge for ease of installation.

One piece **Deep Drawn** sink bowls with integral drainboards with splash.

Featuring the single bowl unit design.

All sink bowls have a large liberal 3" radius.

Placement of the welded leg assembly ensures stability and furnishes direct support of the column load requirement for the entire sink unit.

**CONSTRUCTION:**

All TIG welded.

Welded areas blended to match adjacent surfaces and to a satin finish.

Gussets welded to a die-embossed reinforcing channel.

**MECHANICAL:**

Supply is 1/2" IPS hot & cold.

Faucet holes on 8" centers.

Faucets are not included (see accessories).

Waste drains are 1 1/2" IPS S/S basket type and are included.

**MATERIAL:**

1 5/8" diameter galvanized legs and gussets.

1" adjustable plastic bullet feet.

Bowls are heavy gauge stainless steel type 304 series.

Drainboards, splash and rolled rims are fabricated using heavy gauge stainless steel type 430 series.

One Compartment

Bowl Size	MODEL #	Qty
16 x 20	<b>T9-1-24</b>	
16 x 20	<b>T9-1-24-18R or L</b>	
20 x 20	<b>T9-21-20</b>	
24 x 24	<b>T9-41-24</b>	

Two Compartments

Bowl Size	MODEL #	Qty
16 x 20	<b>T9-2-36</b>	
16 x 20	<b>T9-2-36-18RL</b>	
20 x 20	<b>T9-22-40-18RL</b>	

Three Compartments

Bowl Size	MODEL #	Qty
16 x 20	<b>T9-3-54</b>	
16 x 20	<b>T9-3-54-18R or L</b>	
16 x 20	<b>T9-3-54-18RL</b>	
14" Deep Bowls 16 x 20	<b>T9-3-54-18RLH</b>	
20 x 20	<b>T9-23-60-18RL</b>	
14" Deep Bowls 20 x 20	<b>T9-23-60-24RLH</b>	
24 x 24	<b>T9-43-72-24RL</b>	
20 x 28	<b>T9-83-60-18RL</b>	

Four Compartments

Bowl Size	MODEL #	Qty
16 x 20	<b>T9-4-72-18RL</b>	

ACCESSORIES	MODEL #	Qty
DRAINS		
FAUCETS		

# DETAILS and SPECIFICATIONS

## 12" Water Level Accommodates Pot & Dish Applications

All **Deep Drawn** Sink Bowls Type 304 Stainless Steel.  
All Units Feature Galvanized Legs and Plastic Bullet Feet.

TOL ± .500"  
ALL DIMENSIONS ARE TYPICAL

MODEL #	BOWL SIZE	O.A. Length	# of Comp.	# of Drbds.	A	B	E	Wt
T9-1-24	16x20	25"	1	0	15"	12"	22"	44 lbs.
T9-1-24-18R or L	16x20	40"	1	1	15"	12"	22"	54 lbs.
T9-21-20	20x20	29"	1	0	15"	12"	22"	52 lbs.
T9-41-24	24x24	33"	1	0	15"	12"	22"	76 lbs.
T9-2-36	16x20	44"	2	0	15"	12"	22"	66 lbs.
T9-2-36-18RL	16x20	73"	2	2	15"	12"	22"	73 lbs.
T9-22-40-18RL	20x20	81"	2	2	15"	12"	22"	82 lbs.
T9-3-54	16x20	62"	3	0	15"	12"	22"	81 lbs.
T9-3-54-18R or L	16x20	77"	3	1	15"	12"	22"	87 lbs.
T9-3-54-18RL	16x20	91"	3	2	15"	12"	22"	100 lbs.
T9-3-54-18RLH	16x20	91"	3	2	17"	14"	20"	100 lbs.
T9-23-60-18RL	20x20	103"	3	2	15"	12"	22"	122 lbs.
T9-23-60-24RLH	20x20	115"	3	2	17"	14"	20"	131 lbs.
* T9-43-72-24RL	24x24	127"	3	2	15"	12"	22"	190 lbs.
T9-83-60-18RL	20x28	103"	3	2	15"	12"	22"	200 lbs.
* T9-4-72-18RL	16x20	110"	4	2	15"	12"	22"	185 lbs.

\*Two Faucets Required

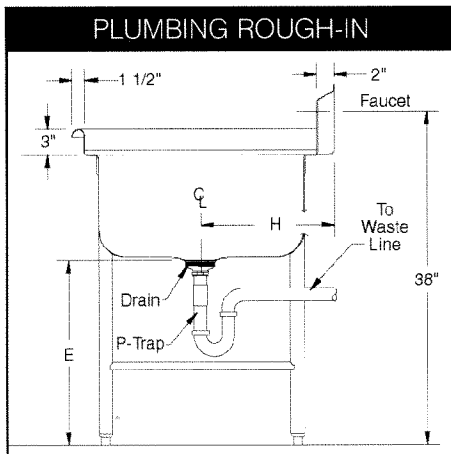
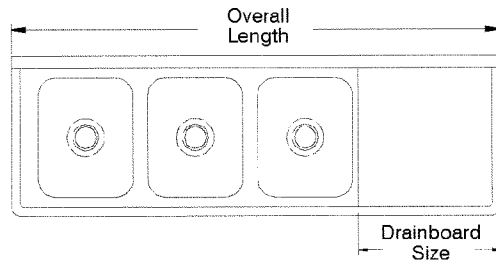

Stainless Steel Basket Type Drains are Standard on All Sinks.

Bowls	F	G	H
16 x 20	27"	20"	14"
20 x 20	27"	20"	14"
24 x 24	31"	24"	16"
20 x 28	35"	28"	18"

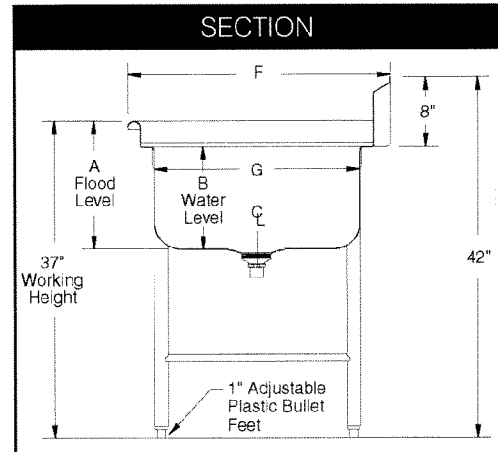

ADVANCE TABCO is constantly engaged in a program of improving our products. Therefore, we reserve the right to change specifications without prior notice.

© ADVANCE TABCO, JANUARY 1999





STAINLESS STEEL  
**DROP-IN SINKS**  
**One Compartment**

For ADA Compliant Sinks add modification # K-148 and Specify bowl depth with a 4 1/2", 5 1/2", 6", 6 1/2"

Item #: \_\_\_\_\_

Model #: \_\_\_\_\_

Project #: \_\_\_\_\_

**SELF-RIM for Hand Sink Use!**

Supplied with K-52 Faucet



DI-1-5



DI-1-10

Model #	Qty
DI-1-5 <b>NSF</b>	
DI-1-10 <b>NSF</b>	
DI-1-25 <b>NSF</b>	
DI-1-30	
DI-1-35 <b>NSF</b>	
DI-1-168	
DI-1-208	
DI-1-2012	
DI-1-2812	



DI-1-25



DI-1-35

**Replacement Faucets**

	Model #	Qty
Deck Mounted Swing	<b>K-50</b>	
Deck Mounted Gooseneck	<b>K-52</b>	
Deck Mtd. 12" Spout	<b>K-53</b>	
Deck Mtd. Large Spout Gooseneck	<b>K-55</b>	
Deck Mounted Swing w/Spray	<b>K-58</b>	
Deck Mounted X.H.D. Gooseneck	<b>K-62</b>	



DI-1-30



DI-1-168

**Supplied with K-53 Faucet**



DI-1-208



DI-1-2012

**LARGEST ONE COMPARTMENT  
 DROP-IN SINK IN THE INDUSTRY!**

Supplied with K-53  
 Faucet with 12" Spout.



DI-1-2812



**NEW YORK**  
 (800) 645-3166  
 Fax: (631) 242-6900

**GEORGIA**  
 (800) 832-1218  
 Fax: (770) 775-5625

**TEXAS**  
 (800) 527-0353  
 Fax: (972) 932-4795

**NEVADA**  
 (800) 446-8684  
 Fax: (775) 972-1578

200 Heartland Boulevard, Edgewood, NY 11717-8380  
 e-mail: [advancetabco@advancetabco.com](mailto:advancetabco@advancetabco.com) [www.advancetabco.com](http://www.advancetabco.com)

# DETAILS and SPECIFICATIONS

TOL ± .250" ALL DIMENSIONS ARE TYPICAL

## TOP for DI-1-5, DI-1-10

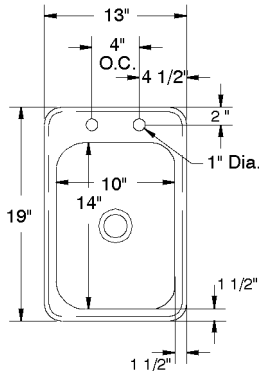

**DI-1-5**  
Cut-out Size  
12 1/4" x 18 1/4"  
1 1/4" radius corners

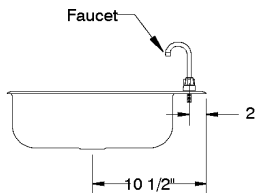
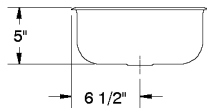

**DI-1-10**  
Cut-out Size  
12 1/4" x 18 1/4"  
1 1/4" radius corners

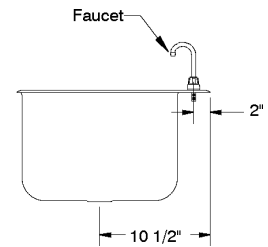
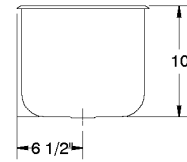

**DI-1-25**  
Cut-out Size  
11 1/4" x 13 1/4"  
1 1/4" radius corners

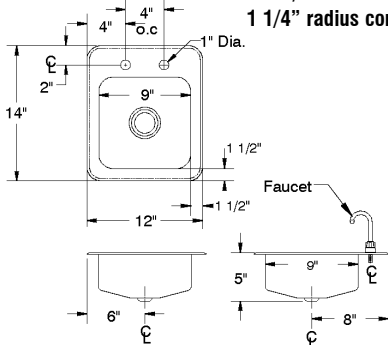

**DI-1-30**  
Cut-out Size  
15" x 14 1/4"  
1 1/4" radius corners

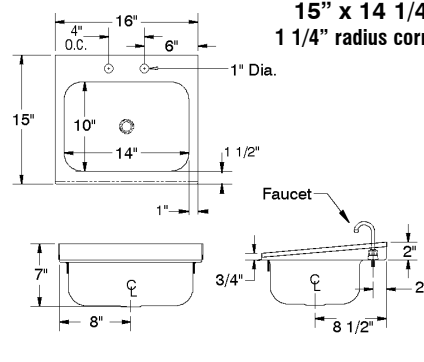

**DI-1-35**  
Cut-out Size  
16 1/4" x 14 1/4"  
1 1/4" radius corners

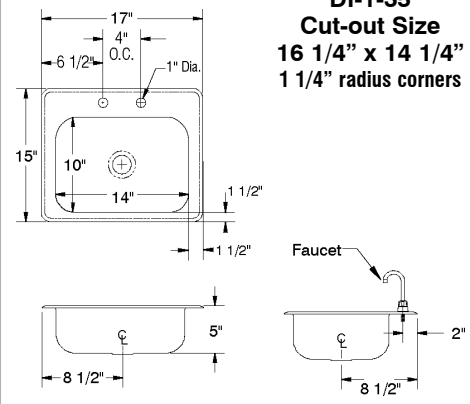

## TOP VIEW DI-1-208 & DI-1-2012

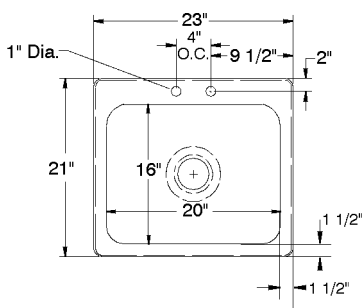

**DI-1-208**  
Cut-out Size  
22 1/4" x 20 1/4"  
1 1/4" radius corners

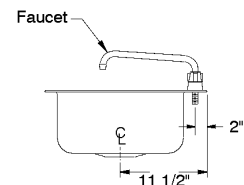
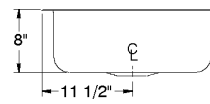

**DI-1-2012**  
Cut-out Size  
22 1/4" x 20 1/4"  
1 1/4" radius corners

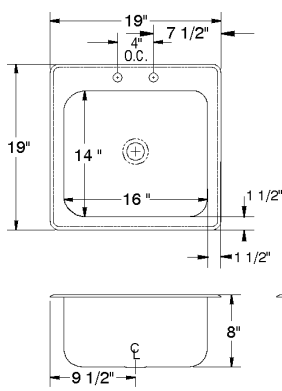
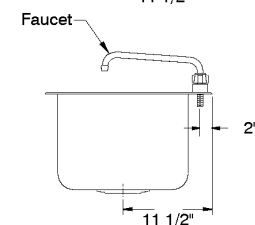
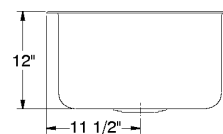

**DI-1-168**  
Cut-out Size  
18 1/4" x 18 1/4"  
1 1/4" radius corners

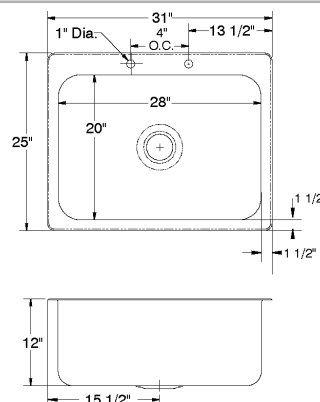
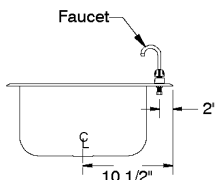

**DI-1-2812**  
Cut-out Size  
30 1/4" x 24 1/4"  
1 1/4" radius corners

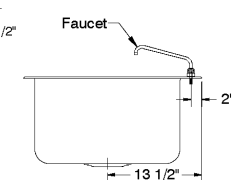



www.cityblends.com

## CITY BLENDS™ JUICE BAR & PROFIT CENTER EQUIPMENT LIST COSTS

ITEM	QTY	DESCRIPTION	UNIT PRICE	TOTAL
1	2	DI-1-5 Advance 1-compart. s/s drop-in sink w/ faucet	138.00	276.00
Option 2	1	DI-3-10 Advance 3-compart. s/s drop-in sink w/ (2) swing spouts faucets	518.00	
	1	B113B T&S Base mount pre-rinse faucet w/ wall bracket	245.00	
				763.00
		OR		
Option 3	1	FC-3-1818-18RL S/S 3-compart. s/s floor style sink w/ legs	840.00	
	1	B-0133-01 Wall mount pre-rinse faucet with wall bracket & add-on swing spout faucet with 12" spout	315.00	
				1,155.00
4	1	AFE400A Scotsman undercounter flaker ice machine		2,595.00
5	1	9324-01 Everpure single cartridge water filter system for above Scotsman flaker		195.00
6	1	TUC-48 True Under counter 2-door refrigerator w/casters		1,599.00
	Terms:	City Blends Charge Card or Certified Check		

\*All suggested product and equipment costs listed, combined with the City Blends™ customer service training and trademarked City Blends™ recipes, creates the streamlined, portion controlled City Blends™ drinks that has made us the best juice bar in the health and fitness industry. The use of other than approved City Blends™ equipment, juices, frozen goods or powders is prohibited. The prices above are provided as an estimate only and are subject to change.